

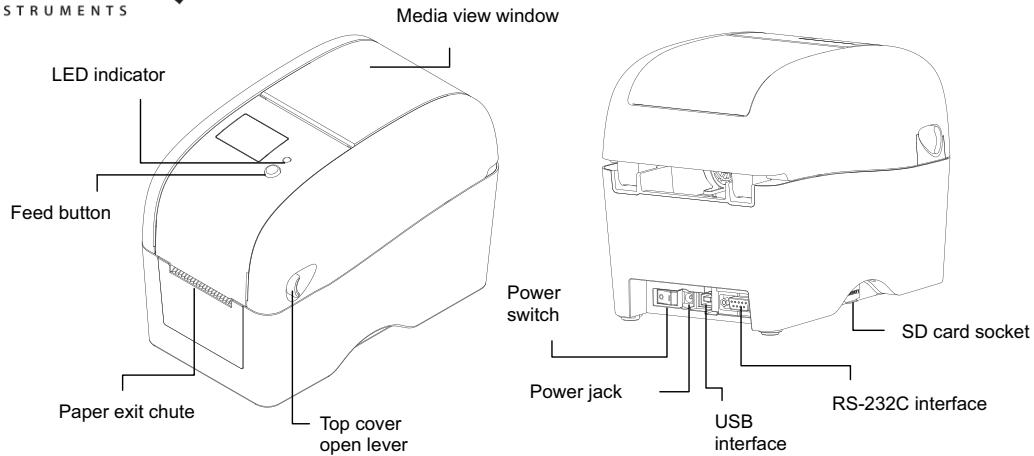

# Wavecom TT04- 50 Quick Installation Guide

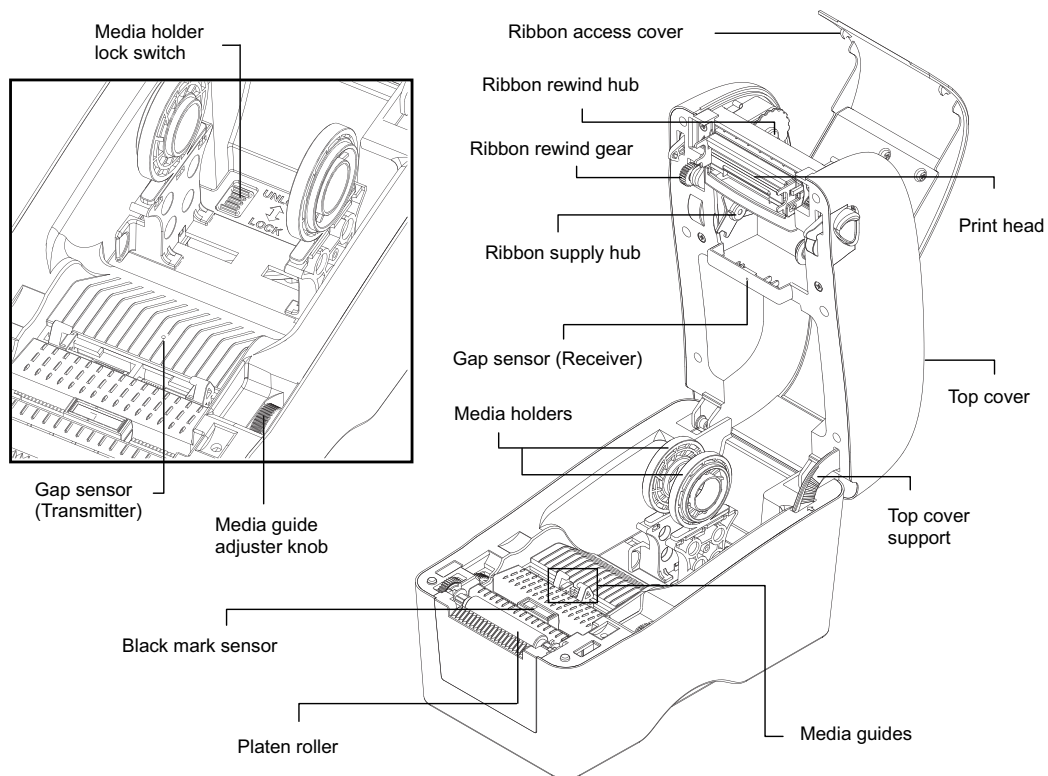

**Note:**  
The interface picture in the quick start guide is for reference only. Please refer to the product specification for the interfaces availability.



## Open / Close the Top Cover

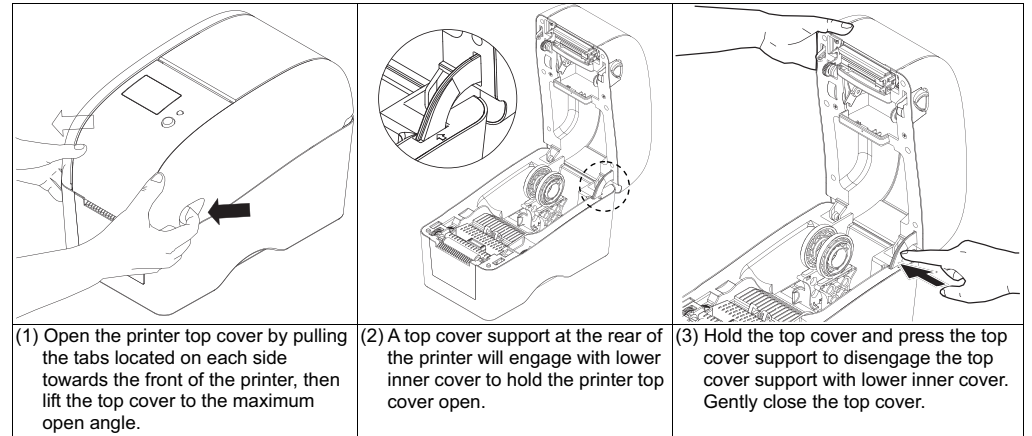

## Loading the Ribbon

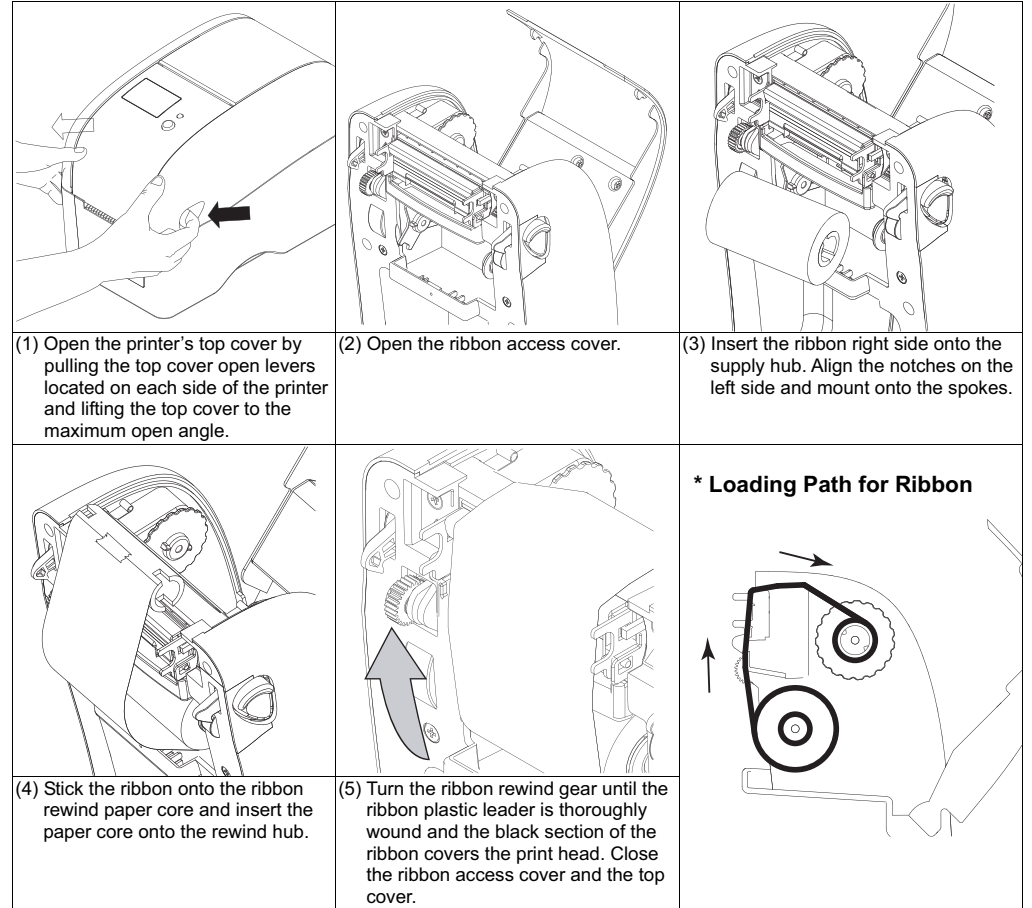

## Loading the Media

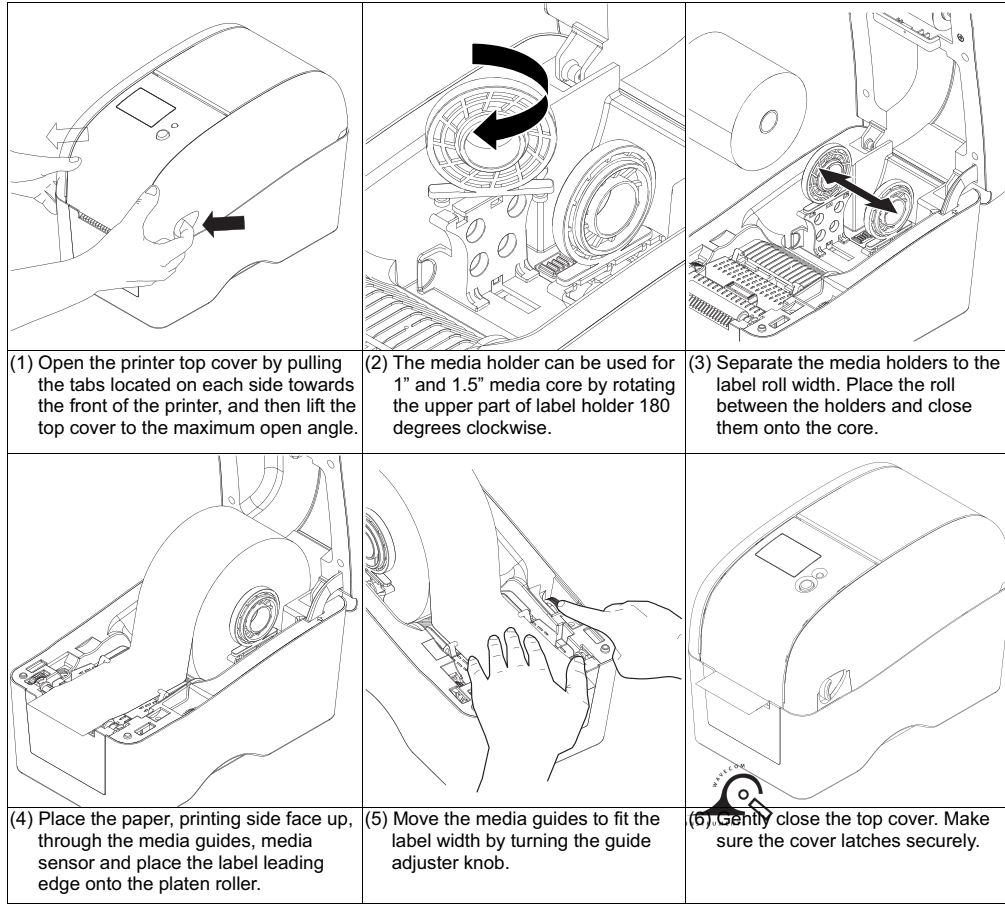

(1) Open the printer top cover by pulling the tabs located on each side towards the front of the printer, and then lift the top cover to the maximum open angle.

(2) The media holder can be used for 1" and 1.5" media core by rotating the upper part of label holder 180 degrees clockwise.

(3) Separate the media holders to the label roll width. Place the roll between the holders and close them onto the core.

(4) Place the paper, printing side face up, through the media guides, media sensor and place the label leading edge onto the platen roller.

(5) Move the media guides to fit the label width by turning the guide adjuster knob.

(6) Gently close the top cover. Make sure the cover latches securely.

### \* Loading Path for Media

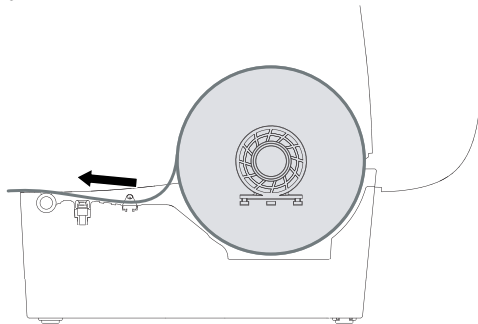

(7) Use "Power On Utility" to scalibrate the black mark sensor. With printer OFF hold in FEED button and power ON. Release FEED button after LED has flashed RED five times. See User Manual.

**Note:**  
Please calibrate the gap/black mark sensor when changing the media.

## Button Functions

### (1) Feed labels

When the printer is ready, press the button to feed one label to the beginning of next label.

### (2) Pause the printing job

When the printer is printing, press the button to pause a print job. When the printer is paused the LED will blink green. Press the button again to continue the printing job.

### Note:

- \* For more information and features about this printer, please refer to the User's Manual inside the CD disk.
- \* Please switch OFF printer power switch prior to plug in the power cord to printer power jack.
- \* Specifications, accessories, parts and programs are subject to change without notice.