

Wavecom

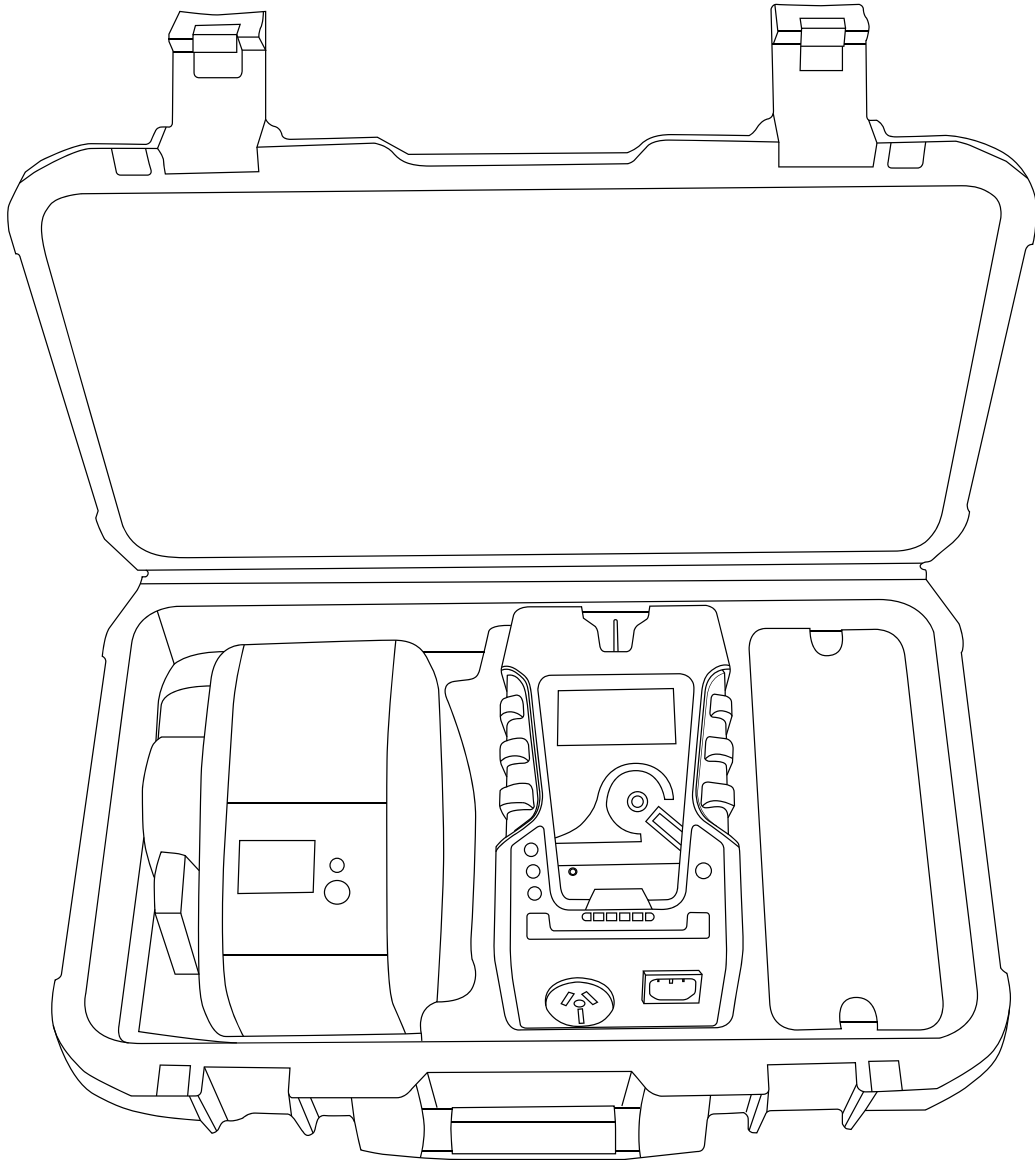

TnP 3PLM 20A/32A/50A
Portable Appliance Test and Print Kit

Quick Start Guide

Safety Recommendations

The TnP 3PLM has been designed to meet stringent safety requirements, however no device can completely protect you from the consequences of incorrect use. The testing of electrical appliances requires that extra care and caution is taken at all times to ensure personal safety.

The Manufacturer also advises that appliance testing should be conducted by a *Competent Person* who is suitably trained (see P.5 AS/NZ 3760:2010 for the definition of *Competent Person*), as well as any additional legislation or rulings in different states. If in doubt, the manufacturer suggests the user contact their responsible authority.

For maximum safety, always ensure that the following advice is followed:

- The equipment being tested is in good condition and passes a visual check.
- All instructions are read, understood and followed.
- The power supply connections are always checked - if the N-E (middle) LED Indicator flashes red, do not proceed before consulting the manual.
- Always use specified fuses and protection devices.
- Do not use leads that require repair or are damaged.
- If you are unsure, call a licensed Engineer/Electrician.

Kit Overview

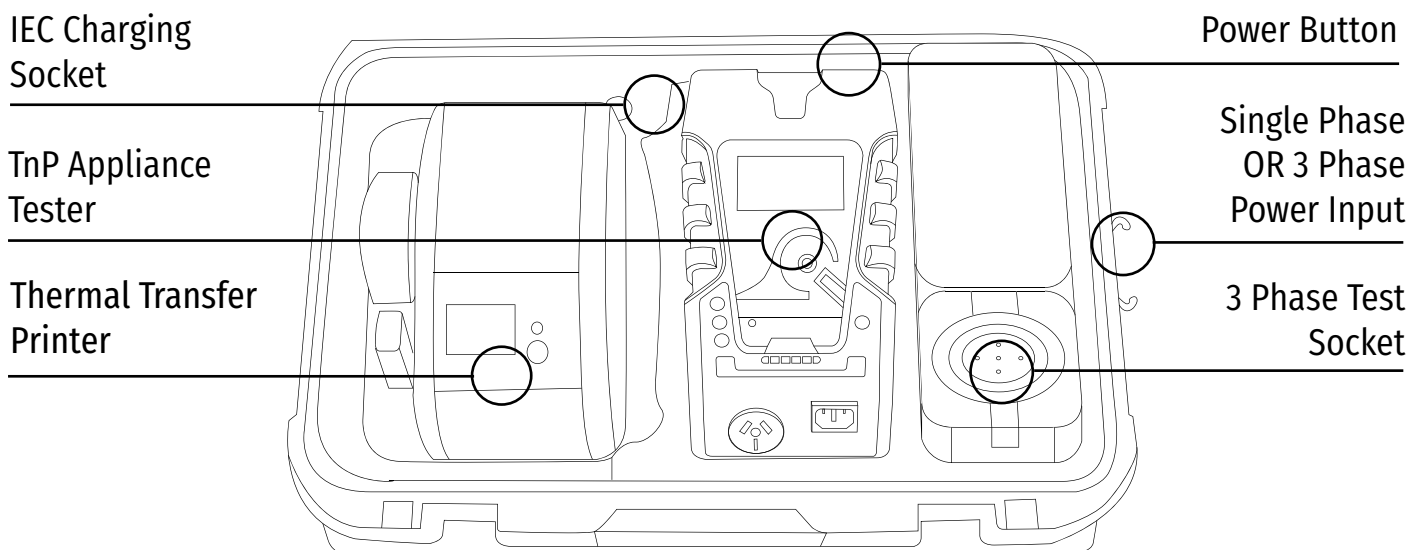

Tester Diagram

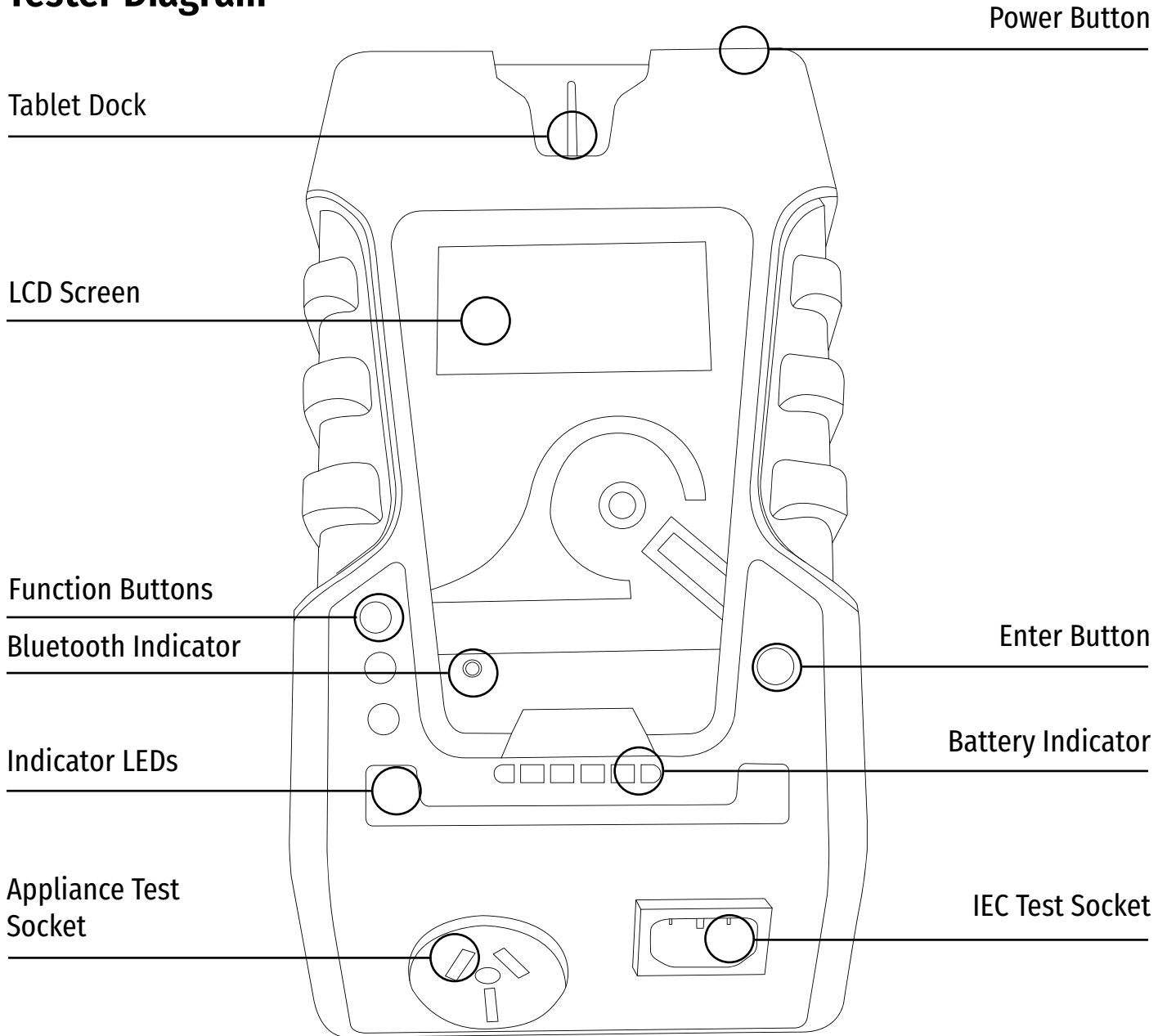

Tester Rear Panel Diagram

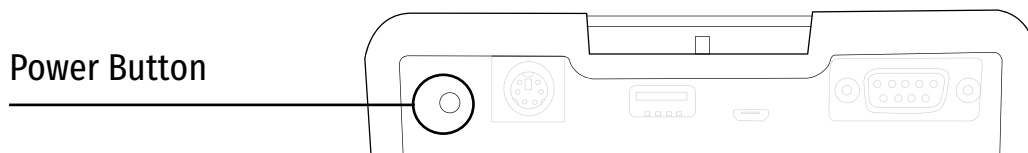

Using your TnP 3PLM

This section will give you the basics you need to operate your TnP 3PLM. For in depth walkthroughs and more detailed information, please refer to the user manual.

To power on your TnP 3PLM, first ensure the Isolation Switch (in the storage compartment) is turned on. Press and hold the small power button above the power socket (on the rear panel of the tester) or the Enter button on the head unit of the tester until the screen comes on and you hear a beep. To power off your tester, hold the power button until your tester beeps and the screen goes dark. If your tester does not turn on, check that the isolation switch on the rear of the tester is switched on. If you are connecting your TnP 3PLM to mains power, it will turn on automatically.

If you are using your TnP 3PLM with the WinPATS App, you will control the tester directly from the app, and you won't need to use the controls on the tester. If you choose to use your TnP 3PLM without the WinPATS App, you will use the Function buttons (F1, F2 and F3) as well as the Enter button to control the tester.

When testing, use the ports on the front of the unit (Appliance Test Socket and the IEC Earth Return). *Do not use the rear IEC power socket for testing, this port is only for charging the TnP 3PLM.*

During testing, you will see the Indicator LEDs flash. The Indicator LEDs will flash during testing when the Appliance Test Socket is live, then turn green or red to denote a pass or fail. Consult the manual for further information about what the indicator LEDs mean.

When your TnP 3PLM is connected to mains power, the N-E (middle LED) indicator may turn red. If so, the Mains Supply Test has failed, and *you should not proceed*. If this occurs consult the manual for further information.

Ensure the battery isolation switch is turned on when unit is in use or connected to mains power. Never turn off the battery isolation switch unless transporting your TnP 3PLM.

Setting up the Barcode Scanner

To use the supplied Bluetooth 1662 BT scanner you will need your tablet and Bluetooth scanner in front of you. Your Bluetooth scanner comes with a quick start guide which may be useful for troubleshooting, but you can set up your scanner using the following instructions. We recommend that you ensure the scanner is fully charged before using it onsite.

First, ensure the battery is installed in your barcode scanner. The LED on your scanner should begin flashing blue, indicating it is ready to be paired to your tablet.

Now, open the Bluetooth Settings menu of your tablet and turn Bluetooth on (if it is not already on). Tap 'Pair New Device' to begin scanning for Bluetooth devices.

Your scanner should appear in the list - you can identify your scanner by the first 4 numbers "1662" followed by the serial number (e.g 1662CFJ000123). The serial number of your scanner is located on the label of your scanner box. Tap your scanner in the list to pair it with your tablet. If you see a prompt to enter a PIN code, simply tap 'Pair' without entering anything - the PIN setting is disabled by default on the scanner and is not required.

Your scanner should now be paired with your TnP 3PLM. To test your scanner, open the WinPATS App and return to the Home screen. Scan one of the barcodes on the outside of the scanner box, and you should see the barcode appear in the 'Search Barcode' field on screen.

Important: After pairing the barcode scanner, you may find that the on screen keyboard of your tablet no longer appears when you tap a text field. To fix this, tap any text field (such as the 'Search Barcode' field on the WinPATS home screen). You will see a keyboard icon appear in the bottom right corner of your screen. Tap this icon, then turn 'Show Virtual Keyboard' on. Your tablet will remember this setting and will display the keyboard from now on.

If you encounter any issues consult the quick start guide included with the scanner, or contact us for support.

Setting up the WinPATS App

Setting up the new WinPATS App is simple, but can take some time. We recommend setting up WinPATS before you need to use it on site. You will need to download "WinPATS Pro" from the Google Play Store onto your Android tablet. On our website, you can find a set of videos that will guide you through the various functions and features of the new WinPATS App. This guide will walk through setting up WinPATS and connecting to your tester.

Once you have downloaded the WinPATS App, open it and create up a 4 digit pin code. This will help keep your data secure.

Next, it's time to set up your Company Account. If your employer or organisation has an account already, you can log in now using the details provided to you. Otherwise, tap Register Company to set up your Company Account - you will be prompted to enable WinPATS' permissions - this allows you to use the full set of WinPATS features.

Now, fill in your details - a valid ABN is required to register a new company. You should use the address and contact details of your head office. Once your details are entered, check they are correct, then tap Register.

You will be sent a One Time Password (OTP) to the email you entered in the previous step. This is used to verify your email address - enter the OTP to continue. This OTP is only valid for 10 minutes - if your OTP expires, simply go back and then tap 'Register' again. If you don't see your OTP email, check your spam folder.

Now you can pay for your WinPATS License - you should have a coupon code on the rear of your TnP 3PLM manual which provides you with one free license for the WinPATS App. Your coupon code is linked to your tester, and you will need to connect your Android tablet to your TnP 3PLM to authenticate your code. Using the USB-OTG cable supplied with your tester, connect your tablet to your tester in the following chain: *Tablet > USB-OTG > USB-A to USB B Cable > USB B port of your TnP 3PLM (located inside the storage compartment)*. Then, enter your coupon code and tap APPLY. You should see the Total Amount number drop to zero. Tap PAY to proceed.

Once you have entered your code or paid, you can now Log In and set up your password. Enter the Company ID and temporary Password which was emailed to you, which will enable you to log in for the first time. You will now be prompted to set up a new password.

You can now set up your User Account - this is your individual profile. If you are the first or the only Test and Tag technician at your organisation, you should set yourself as an 'ADMIN' user, which will allow you to use the full features of WinPATS. Technician users have reduced access to features - this is designed for organisations with multiple technicians and/or multiple sites.

Once your details are complete, tap ADD to create your account. Confirm your details are correct, then tap CONFIRM to finish registering your user account.

When you start WinPATS for the first time you'll be required to perform a data sync. This creates a new cloud database for you, or connects your WinPATS App to your company's existing database. If your database has many items, this may take up to 5 minutes, but usually only takes a few seconds.

Connecting via Bluetooth

To control your TnP 3PLM via Bluetooth, you will need to perform a short setup procedure. Ensure you have both your tablet with WinPATS installed, and your TnP 3PLM in front of you.

Go to the Bluetooth settings in your Tablet's settings menu

Ensure that Bluetooth is enabled, then select your TnP 3PLM from the list of available devices (ensure you select the correct tester by referring to the serial number. Your TnP 3PLM's serial number is located on the side of your tester, and on the rear cover of the TnP 3PLM manual).

You may now be prompted to pair your two devices using a PIN code. If so, your TnP 3PLM will display

a code on the screen. Enter this code into WinPATS and tap OK. You will be asked to confirm the connection - tap Confirm after checking the details are correct. If you have any issues with the PIN code entry, consult the manual.

Go to the WinPATS App

To connect your TnP 3PLM, go to the Test menu in the WinPATS App (at the top of the screen). You should be prompted to connect a Wavecom Appliance Tester as soon as you open the Test Menu for the first time. Tap 'BLUETOOTH' to begin the Bluetooth setup process.

WinPATS will scan for any available TnT or TnP testers and display them in a list - select your tester from the list by tapping it. If you see multiple TnT or TnP products in the list, use the serial number of your TnP to identify your tester.

You will now be asked to register your TnP 3PLM - this allows you to receive product support, service and calibration reminders from Wavecom. Once complete, tap Register. You're now ready to start testing with WinPATS!

For more information and step by step guides for using WinPATS, consult your manual, or visit our website: www.wavecom.com.au/winpats.php

Using your TnP 3PLM without the WinPATS App

Your TnP 3PLM can be used without connecting it to the WinPATS App, though this will limit the features available to you.

In Tester Mode, you will be able to use your TnP 3PLM as a simple appliance tester. In this mode, *results will not be recorded.*

Once your tester is on, you will see Main Menu A on your screen. You can navigate between Main Menu A and B using the Enter Button, and select a test to run using the F1, F2 or F3 buttons.

To run a test, you should first set up the item to be tested. When ready, select a test from Main Menu A or B using the corresponding button (F1, F2 or F3). If you are conducting a Leakage or RCD, you will be taken to a sub-menu where you can select which Leakage or RCD test to run.

Follow the on screen prompts to begin the test. Your test will be conducted automatically in stages. If the test requires your item to be powered, a warning will display on screen so you can ensure the item can be powered on safely before proceeding. During the test, the indicator LEDs will flash to indicate a test is underway.

Once your test is complete, the indicator LEDs will flash green (for Pass) or red (for Fail), and your results will be displayed on screen. You will then be returned to the Main Menu.

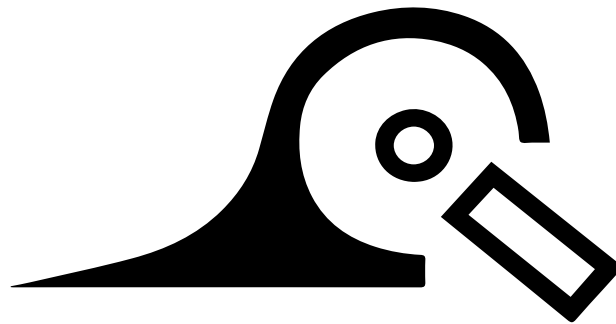

The TnP 3PLM is proudly designed and manufactured in
Australia by Wavecom.

Wavecom SA

257 Grange Road,
Findon SA, 5023

08 8243 3500
service@wavecom.com.au

Wavecom WA

Unit 2/17 Casino Street,
Welshpool WA, 6106

08 9353 1943
saleswa@wavecom.com.au

Wavecom VIC

Mark Kennedy
M: 0430 299 164

03 9897 4711
service@wavecom.com.au